

➤ Dimensions for Pipe Support

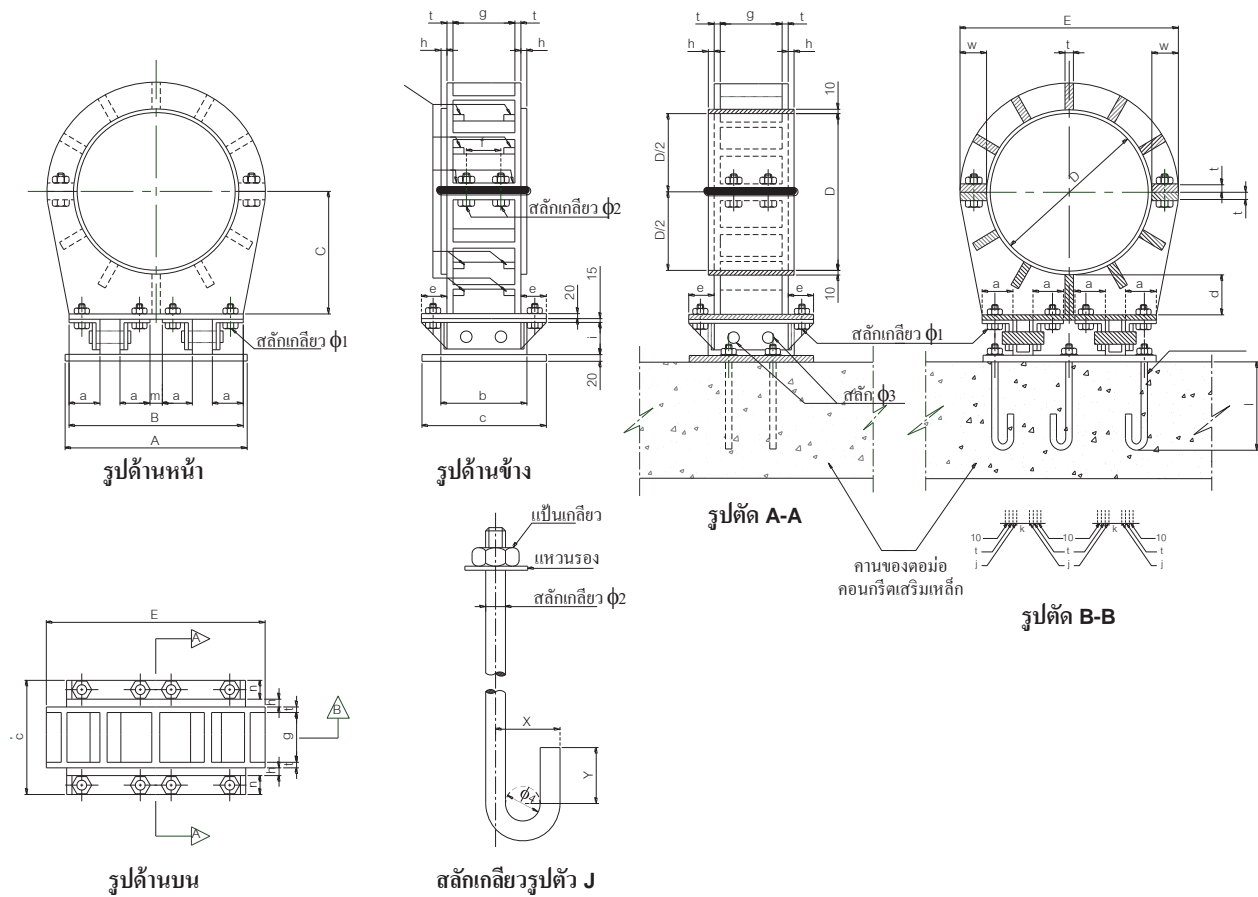

Unit : mm.

ND.	A	B	C	D	E	a	b	c	d	e	f	g	h	i	j	k	l	m	n	t	w	Ø1	Ø2	Ø3
400	0.48	0.46	0.31	0.412	0.572	0.07	0.21	0.31	0.094	0.07	0.08	0.15	0.020	0.10	0.01	0.05	0.25	0.04	0.05	0.01	0.07	16	20	0.04
500	0.58	0.52	0.36	0.514	0.674	0.07	0.21	0.31	0.093	0.07	0.08	0.15	0.020	0.10	0.01	0.08	0.25	0.04	0.05	0.01	0.07	16	20	0.04
600	0.68	0.60	0.46	0.616	0.796	0.07	0.24	0.34	0.142	0.07	0.10	0.18	0.020	0.10	0.01	0.12	0.30	0.04	0.05	0.01	0.08	16	22	0.04
700	0.78	0.70	0.51	0.717	0.917	0.09	0.29	0.42	0.142	0.09	0.10	0.20	0.025	0.12	0.015	0.12	0.30	0.04	0.065	0.02	0.09	20	27	0.04
800	0.88	0.80	0.59	0.819	1.039	0.10	0.31	0.46	0.170	0.10	0.11	0.22	0.025	0.12	0.015	0.15	0.30	0.04	0.075	0.02	0.10	22	30	0.04
900	0.98	0.90	0.64	0.920	1.180	0.10	0.33	0.48	0.170	0.10	0.12	0.24	0.025	0.15	0.015	0.20	0.40	0.04	0.075	0.02	0.12	22	33	0.04
1000	1.08	1.00	0.69	1.022	1.282	0.10	0.33	0.48	0.169	0.10	0.12	0.24	0.025	0.15	0.015	0.25	0.40	0.04	0.075	0.02	0.12	24	33	0.04
1200	1.28	1.20	0.81	1.225	1.485	0.10	0.33	0.48	0.187	0.10	0.12	0.24	0.025	0.15	0.015	0.35	0.40	0.04	0.075	0.02	0.12	24	33	0.04
1500	1.60	1.56	1.025	1.530	1.910	0.14	0.40	0.62	0.250	0.14	0.15	0.30	0.04	0.02	0.02	0.43	0.60	0.06	0.10	0.02	0.18	33	42	0.04

Diameter of Bolts (mm.)	16	20	22	24	27	30	33	42
Pitch (mm.)	2	2.5	2.5	3	3	3.5	3.5	4.5

Bolts Dia. Ø2 mm.	Pitch mm.	Min Dia. Ø4 cm.	Y cm.	X cm.
20	2.5	12.0	8.0	16.0
22	2.5	13.2	8.8	17.6
27	3	21.6	10.8	27.0
30	3.5	24.0	12.0	30.0
33	3.5	26.4	13.2	33.0
42	4.5	42.0	16.8	50.4

Note: 1. All dimensions are in meters unless otherwise shown.
2. Pitch of bolts shall be as follow.